

INSTALLATION GUIDE FOR PV MODULES

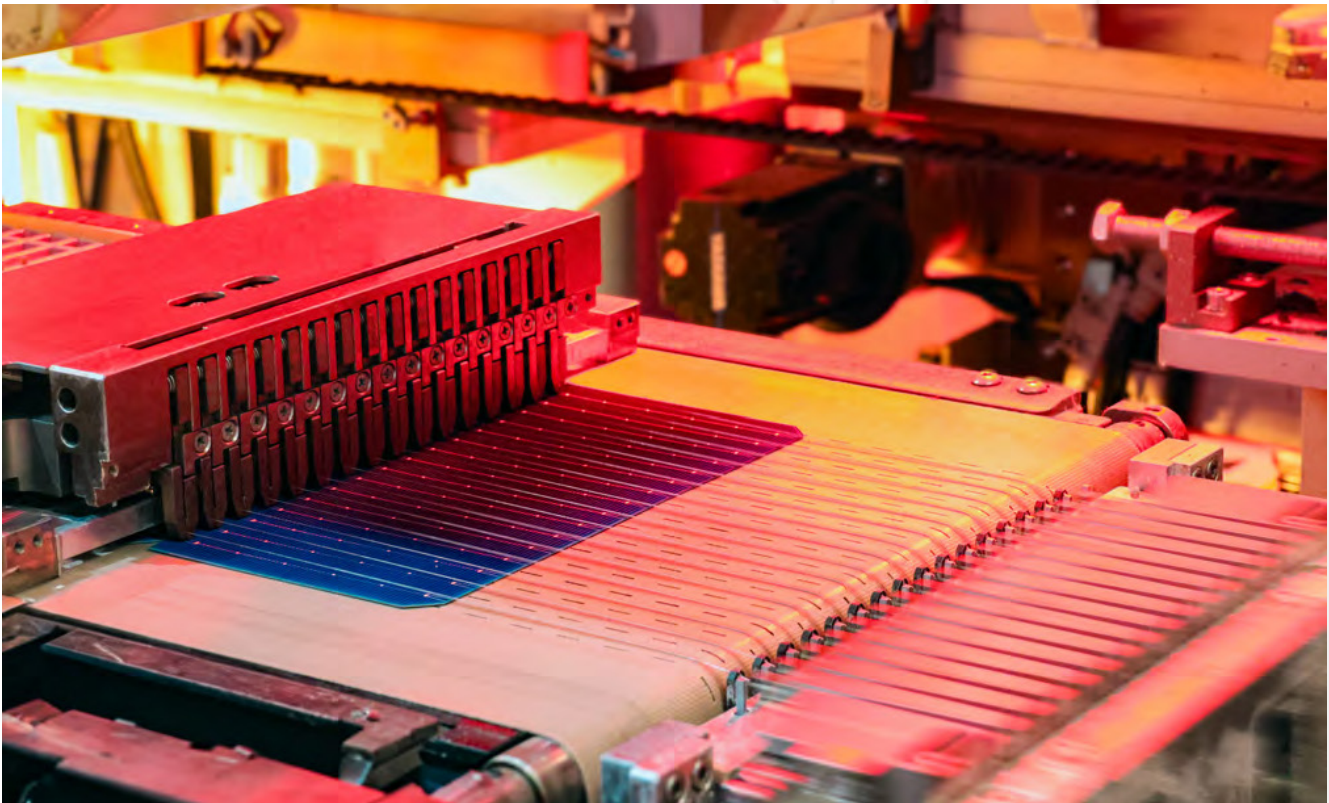

TS EN 61215, TS EN 61730
 IEC 61215, IEC61730, IEC 62804 (PID Free)
 UL 61730-1, UL 61730-2
 ISO 9001:2015 / Quality Management System
 ISO 14001:2015 / Environmental Management System
 ISO 45001: 2018 / Occupational Health and Safety Management System
 ISO 50001:2018 / Energy Management System
 ISO 27001:2013 / Information Security Management System
 ISO 10002:2018 / Customer Satisfaction Management System
 ISO 37001:2016 / Anti-Corruption Management System
 ISO 26000:2021 / Social Responsibility Management System



| 1 PURPOSE OF THIS GUIDE

We appreciate your selection of SIRIUS Photovoltaic Modules (hereinafter referred to as “PV Modules”). This guide provides detailed instructions for the proper application of SIRIUS PV modules. Installers are required to thoroughly read and comprehend this guide prior to installation. For any inquiries please contact our technical department at info@siriuspv.com for additional support. Installers must adhere to all safety precautions outlined in this Guide and comply with local codes during module installation. Retain this Guide in a secure location for future reference (including care and maintenance) and for potential sale or disposal of the PV modules.

| 2 SAFETY

2.1 GENERAL SAFETY

The PV modules are certified for application class A suitable for use in systems operating at voltages exceeding 50V DC or power outputs above 240W where general communication access is expected. PV modules meeting safety standards as defined in this section of IEC 61730 and IEC 61730-2 within this application class are deemed to satisfy the requirements for safety class II.

- The PV modules must be properly grounded in accordance with the guidelines outlined in this Guide or the stipulations of the National Electrical Code (NEC) and Canadian Electrical Code (CEC) as applicable.
- The installation of PV modules demands specialized skills and expertise and should only be undertaken by qualified personnel. Electrical connections must be executed by a licensed electrician in compliance with local codes (e.g., NEC for the USA and CEC for Canada).
- Installers are responsible for assuming all risks of injury that may arise during installation including but not limited to the risk of electric shock.
- A single PV module may produce a voltage exceeding 30V DC when exposed to direct sunlight. Access to DC voltages of 30V or higher poses a potential hazard.
- PV modules are engineered for outdoor use and designed to convert light energy into DC electrical energy. They may be installed on ground surfaces, rooftops, vehicles, boats or similar structures with the proper design of support structures being the responsibility of system designers and installers.
- Refrain from using mirrors or other magnifying devices to focus sunlight onto the PV modules.
- During installation of the PV modules compliance with all local, regional and national regulations is mandatory. Secure a building permit if required.
- Utilize only equipment, connectors, wiring and support frames that are fully compatible with the PV modules.
- Avoid cleaning the modules with chemicals.



2.2 PACKAGE OPENING

2.2.1 Remove the stretch film and carefully cut the outer strips. (Drawing 1.1)

2.2.2 Remove the packaging cardboard. (Drawing 1.2)

2.2.3 Position the unpacking bracket (or in the absence of a bracket, stabilize the package against a sturdy object or surface) ensuring the bracket is wider or taller than the module to avoid damage from potential collision with the glass on the PV module. (Drawing 1.3)

2.2.4 Cut all horizontal strips and once 1-2 vertical seal strips remain, gently slide the component toward the bracket or fixed support. (Drawing 1.4)

2.2.5 Cut the remaining strips. (Drawing 1.5)

2.2.6 The PV modules must be transported with care by a minimum of two individuals. (Drawing 1.6)

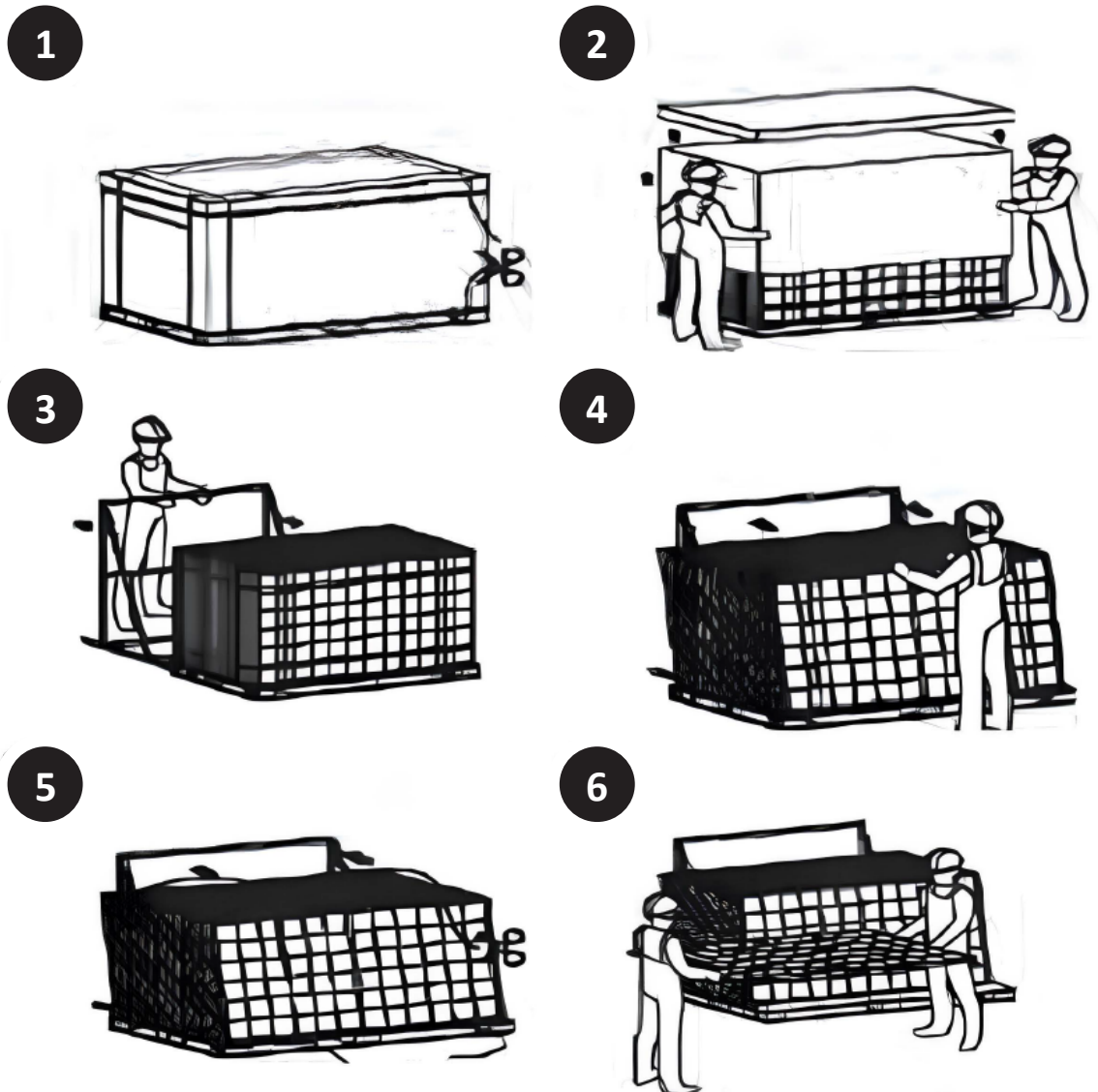

Drawing 1

2.3 TRANSPORT SAFETY

- Avoid lifting the PV module by holding the junction box or electrical leads.
- Refrain from stepping on the PV modules, placing heavy objects on them or exerting pressure.
- Prevent the PV module from being dropped or allowing objects to fall onto it.
- Handle the PV modules with care during movement, transportation and installation.
- Do not prop the PV modules against other objects.
- When stacking PV modules, utilize soft protective materials to separate them and safeguard their integrity.
- Do not attempt to disassemble the PV modules and ensure that no labels (power and / or frame) or components are removed.
- Avoid applying paint or adhesive to the upper surface of the PV module.
- Prevent scratching or damaging the backsheet.
- Do not drill holes in the frame as this may compromise the frame's mechanical strength and potentially cause microcracks in the cells due to vibration.
- Avoid breaking or scratching the anodized coating of the frame (except at the grounding connection) as this may result in corrosion or rust formation on the frame.
- Do not utilize PV modules with broken glass or a torn backsheet as these conditions present an electric shock hazard.
- Refrain from operating PV modules in wet conditions unless they are adequately protected.
- Prevent exposure of the PV module to sunlight prior to installation to minimize unnecessary degradation.
- During transportation ensure that no excessive vibration occurs which could lead to microcracks in the cells or damage to the module.
- PV module pallets must be shipped solely when stacked with two pallets securely fastened together for shipping purposes. Upon completion of shipment, the dual pallet group should be stored and transported as follows:
 - ◊ For on-site storage, pallets must be kept separate from one another with each package stored individually on a flat surface.
 - ◊ On-site horizontal and vertical movements should be performed using a single pallet. Failure to do so may alter the center of gravity and force pressure points, potentially damaging both the package and the PV module inside thereby voiding warranty conditions.
 - ◊ All pallets stored on-site must be housed in an enclosed space or covered with a tarpaulin-like covering.
 - ◊ PV modules shall be transported sequentially in a controlled manner by a minimum of two individuals either horizontally or vertically.

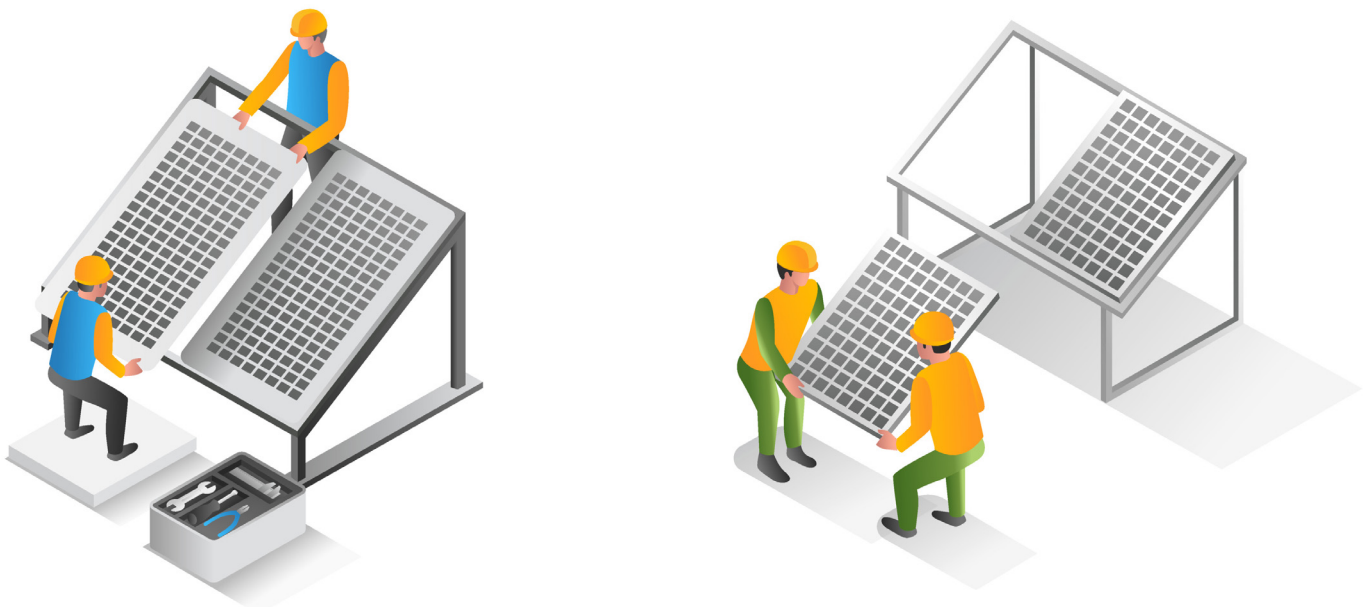

2.4 INSTALLATION SAFETY

- Installation must comply with the IEC standard, Safety Standard for Electrical Installations.
- Avoid disconnecting under load.
- Do not contact conductive parts of PV modules such as terminals which may cause burns, sparks or lethal shock regardless of whether the PV module is connected.
- Refrain from unnecessary contact with the PV module during installation.
- Avoid working in rainy, snowy or windy conditions.
- Do not expose the PV modules to artificial sunlight. Fully cover the PV module with an opaque material during installation to prevent electricity generation.
- Do not wear metallic rings, watchbands or other metallic objects including ear, nose and lip rings while installing or troubleshooting.
- Utilize only insulated tools that are certified for use in electrical installations.
- Adhere to safety regulations for all other system components including wires, cables, connectors, charging regulators, inverters, storage batteries, rechargeable batteries and similar equipment.
- Under typical outdoor conditions, the current and voltage generated may deviate from the values specified in the datasheet. When designing systems, multiply the current and short-circuit current by a factor of 1.25 to establish appropriate component ratings.
- Utilize only connectors that are fully compatible with the PV module connectors. Unauthorized removal of connectors will result in warranty invalidation.
- Disassembly, dismantling or removal of installed modules without prior permission will void the warranty.
- Avoid transferring installed modules to another project as this may lead to warranty invalidation.
- Do not install modules within 50 meters of the shoreline.

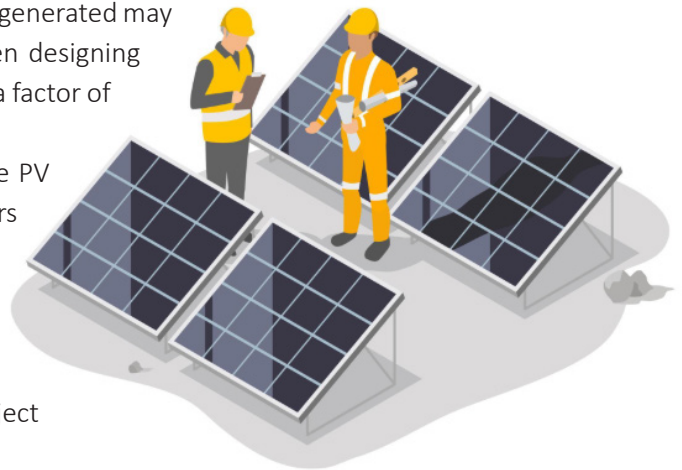

2.5 FIRE SAFETY

- The fire rating of this module remains valid solely upon adherence to the guidelines outlined in this Guide.
- Contact your local authority to obtain guidelines and requirements for building or structural fire safety.
- Avoid using PV modules in proximity to equipment or in locations where flammable gases may be produced.
- Comply with all applicable local codes and laws during the installation of the modules.

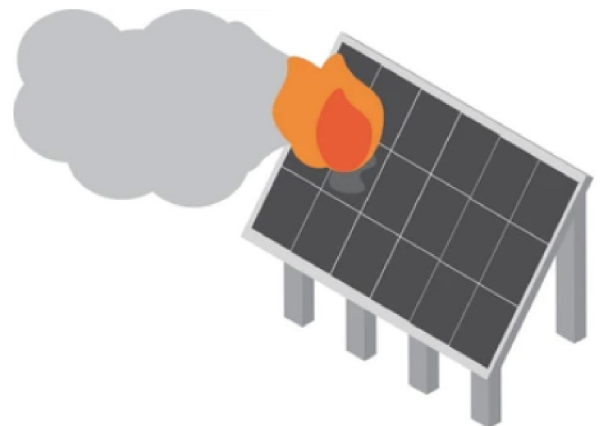

2.6 REPACKAGING OF PV MODULE *

2.6.1 PV MODULE DISMANTLING PROCEDURE

- Prior to disconnecting the electrical connections of the PV module, the inverter’s DC circuit breaker must be switched off and it must be confirmed that the system is fully de-energized.
- Before separating connection points, connectors must be thoroughly inspected for indications of damage including burns, corrosion or looseness. Any detected damage must be reported.
- The four clamps utilized to detach the mounted PV module from the structure must be removed using an M8 Allen key.
- Subsequently the connectors of the PV module must be disconnected with the assistance of a circlip plier or connector crimping plier.
- Appropriate insulated gloves and tools are required during the disconnection of electrical connections.
- The surface of the PV module must be meticulously inspected and any scratches, cracks or other physical damage must be documented.
- Prior to removing the PV module’s frame and mounting components, it must be verified that the screws are neither loose nor deformed.
- To safeguard the PV module from damage during transport adherence to the instructions outlined in “2.3 Transport Safet” is mandatory. Original packaging or materials offering equivalent protection must be utilized.
- In cases where unpackaged PV modules require transportation to another location, they must be repackaged collectively up to the maximum permitted number per package, secured with internal packaging straps. The package must then be enclosed in a cardboard box and fastened with an identical number of packaging straps as previously used.
- Should the number of modules to be packaged fall below the maximum allowed per package, PV modules must be secured either at the center of the pallet for auxiliary packaging or along the side for distribution packaging and fastened with internal packaging straps. During transport of a partially packaged unit, it must not be positioned on the bottom layer.

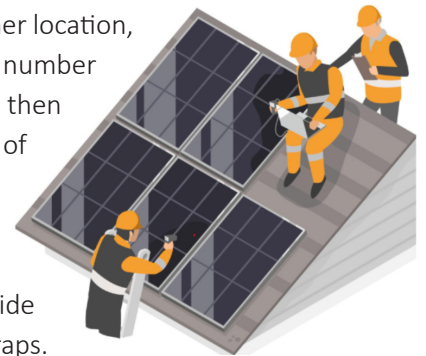

2.6.2 SHIPMENT PROCEDURE

- The suitability of the vehicle designated for shipment must be confirmed. The vehicle must provide adequate space and appropriate securing equipment to guarantee that PV modules are transported without damage.
- PV modules must be supported with foam or comparable shock-absorbing materials to mitigate damage from impact or vibration. During transportation, the package must be firmly fastened with packing straps to eliminate any movement on the transport platform.
- Should external logistics or technical service providers be engaged for shipment or inspection, it must be verified that these entities operate in accordance with our operational standards and that the scope of the agreement is explicitly defined.



* Sections 2.6.1 and 2.6.2 outline the procedures to be followed in instances where the manufacturer issues a product recall.

| 3 PRODUCT DESCRIPTION

Each PV module is assigned a unique serial number. Additionally every module features three barcode stickers, each bearing this serial number along with a single power label affixed to the back side.

Barcode 1: Permanently laminated onto the PV modules.

Barcode 2: Affixed to the backside of the PV modules.

Barcode 3: Positioned in the central location along the long frame side.

Label: Attached to the backside of the PV modules, detailing the characteristic parameters of the modules. Verify the serial number on the barcode against the packing list during unpacking. Submit the PV module’s serial number when requesting support from “SIRIUS” for specific PV modules.

3.1 FRAME DRAWINGS

Our PV modules are produced with a composite frame as the standard configuration. Alternatively an aluminum frame option is also offered. You may examine the aluminum frame drawings for PV modules featuring rectangular cell structures in the dimensions of 2382 x 1134 mm (ELNSM66M-HC-HV-N) and 1762 x 1134 mm (ELNSM48M-HC-HV-N) and 1722 x 1134 mm (ELNSM54M-HC and ELNSM54M-HC-N) in the subsequent sections.

- **Drawing 2:** Aluminum (Glass-Glass) 2382 × 1134 mm
- **Drawing 3:** Aluminum (Glass-Glass) 1762 × 1134 mm
- **Drawing 4:** Aluminum (Glass-Backsheet) 2382 × 1134 mm
- **Drawing 5:** Aluminum (Glass-Backsheet) 1762 × 1134 mm
- **Drawing 7:** Aluminum (Glass-Backsheet) 1722 × 1134 mm

The technical drawings of composite frames for TOPCON modules (Glass-Glass and Glass-Backsheet) are included in Drawing 6. The aluminum frame drawings are available in the technical datasheet of the corresponding product.

Table 1

MODULE	DIMENSIONS	FRAME	WEIGHT (KG)	PV MODULES PER PALLET	PV MODULES PER UNIT	TOTAL CONTAINER CAPACITY
66HC-G2G	2382 x 1134 x30	AL	33,3	36	20	720
66HC-G2B	2382 x 1134 x35	AL	27,9	31	20	620
48HC-G2G	1762 x 1134 x30	AL	24,8	36	24	864
48HC-G2B	1762 x 1134 x35	AL	20,9	31	24	744

*

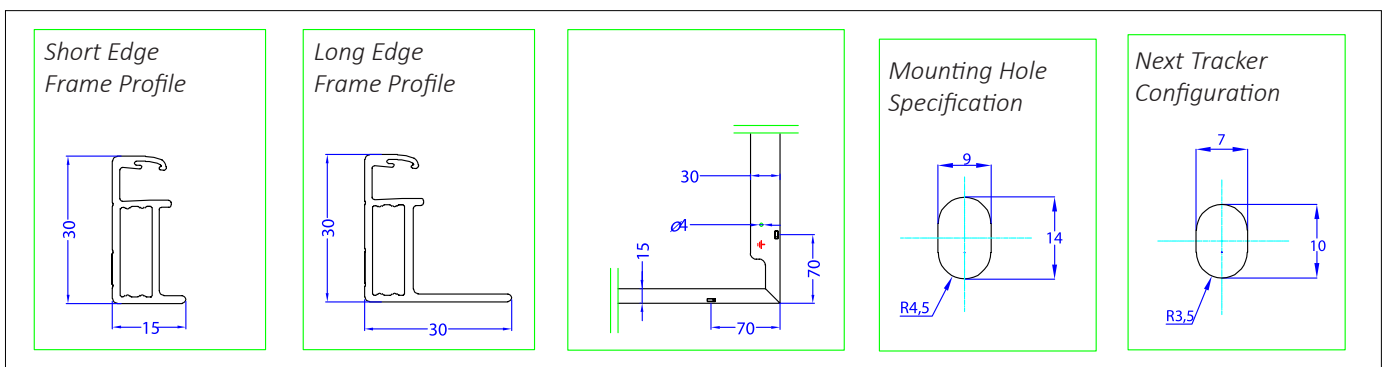

Drawing 2 Aluminum (Glass-Glass) 2382/1134

*

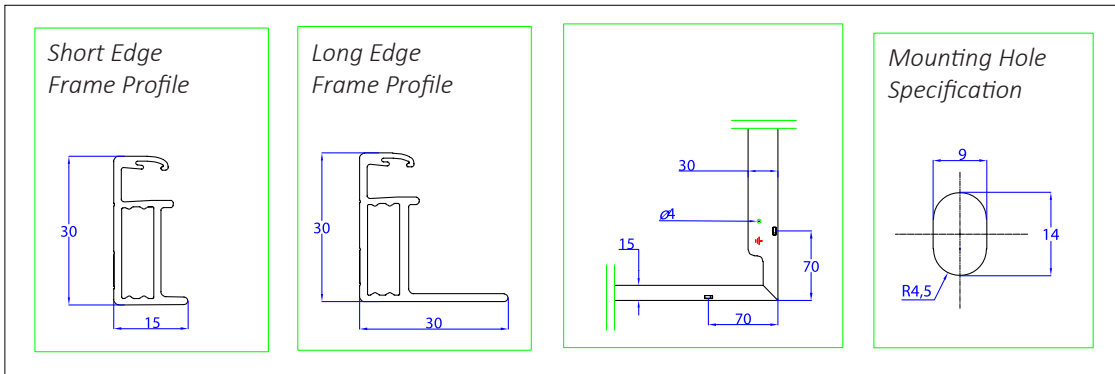

Drawing 3 Aluminum (Glass-Glass) 1762/1134

*

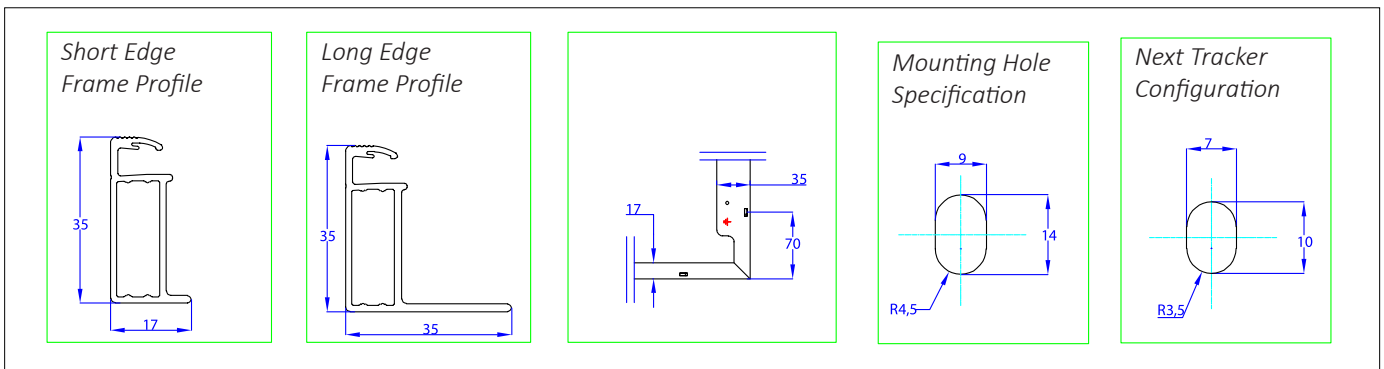

Drawing 4 Aluminum (Glass-Backsheet) 2382/1134

*

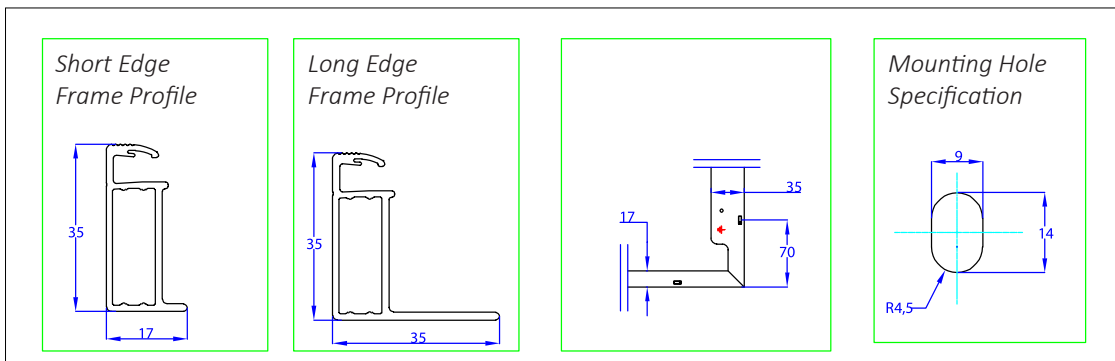

Drawing 5 Aluminum (Glass-Backsheet) 1762/1134

*

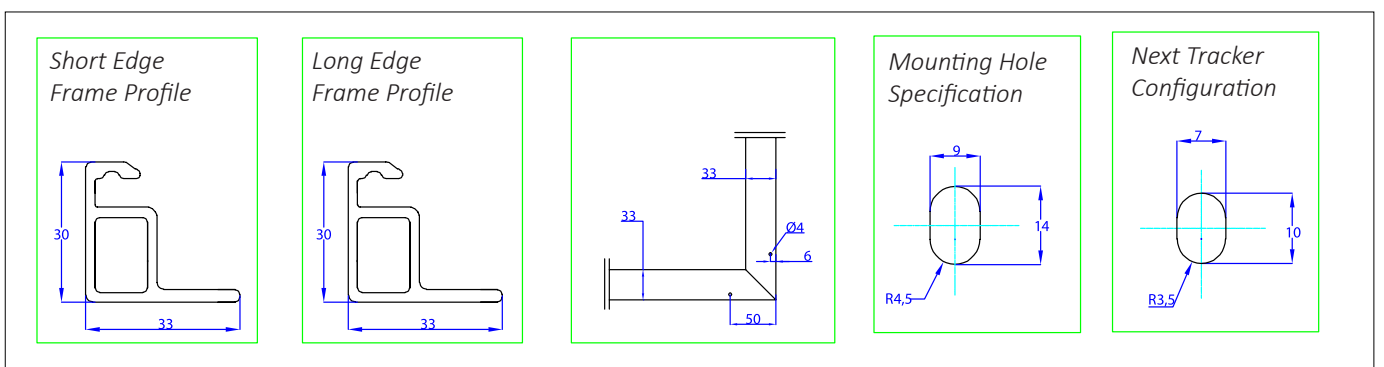

Drawing 6 Composite (Glass-Glass and Glass-Backsheet) TOPCON PV Modules

*

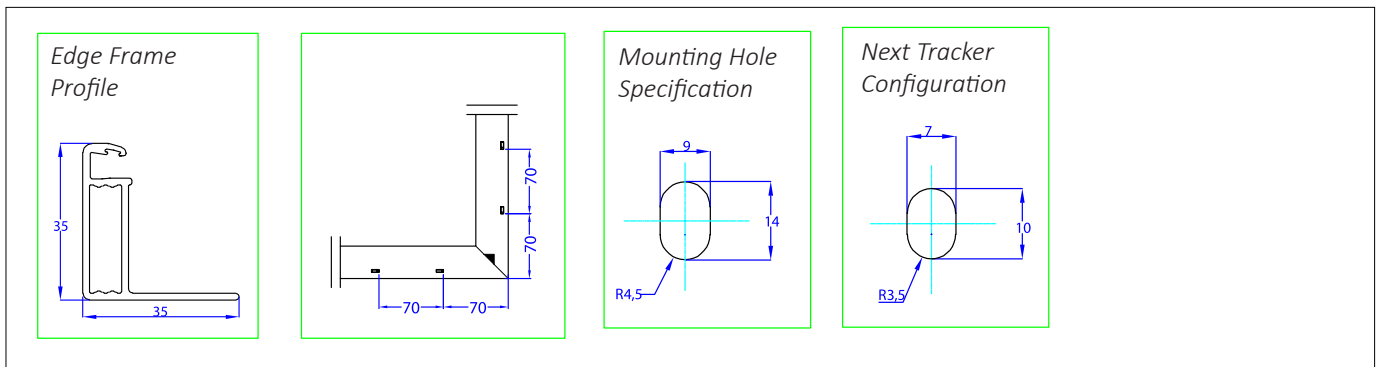

Drawing 7 Aluminum (Glass-Backsheet) 1722 / 1134

4 MECHANICAL INSTALLATION

4.1 GENERAL INSTALLATION PRINCIPLE

- PV modules may be installed in either horizontal or vertical orientations.
- Clamps must not obstruct the front surface of the cells.
- It is advised to install modules of uniform size and type within a single PV array.
- PV modules must be positioned at an adequate height to prevent potential shading, flying sand, snow and water accumulation.
- It is advised to position PV modules at a minimum height of 30 cm above the ground to ensure optimal ventilation.
- Bifacial modules must be installed at a minimum height of 1 meter above the ground or roof to preserve their energy efficiency.
- Suitable installation structures must be chosen to comply with the specified mechanical load requirements.
- It is advised to install PV modules at a minimum angle of 10 degrees to promote effective dust removal.
- It is advised to maintain a minimum gap of 2 cm between PV modules to accommodate thermal expansion of materials.
- It is advised to ensure proper alignment in accordance with the corresponding mechanical load specifications.

4.2 LOCATION AND ANGLE SELECTION

- It is advised to install PV modules in regions characterized by excellent sunlight resources. In the Northern Hemisphere, modules should generally be oriented southward whereas in the Southern Hemisphere, they should typically be oriented northward. The optimal installation angle is contingent upon varying latitudes and longitudes; consult with qualified experts when determining installation locations and angles.
- When selecting a site, ensure the avoidance of trees, buildings or other obstructions that may cast shadows on the solar photovoltaic modules. Shading may lead to hotspots and reduced output though the factory-installed bypass diodes in the PV module will mitigate this impact.
- Prohibit the installation of the PV module in proximity to open flames or flammable materials.
- Prohibit the installation of the PV module in areas where it would be submerged in water or persistently exposed to water from sprinklers, fountains or similar sources.

4.3 SCREW INSTALLATION

4.3.1 GENERAL INSTALLATION PRINCIPLE

The PV module is engineered for installation utilizing a clamp. For secure attachment to the bracket, bolts, nuts and washers are required (as depicted in Figures 1 and 2).

To guarantee a robust and secure fixation adequate torque must be applied to the bolts. The specified torque value for an M8 bolt is 16-20 N-m. It is recommended to employ a fastener capable of supporting at least an M8 bolt accompanied by the appropriate spring washers.



Figure 1 Double-Sided Clamp



Figure 2 Single-Sided Clamp

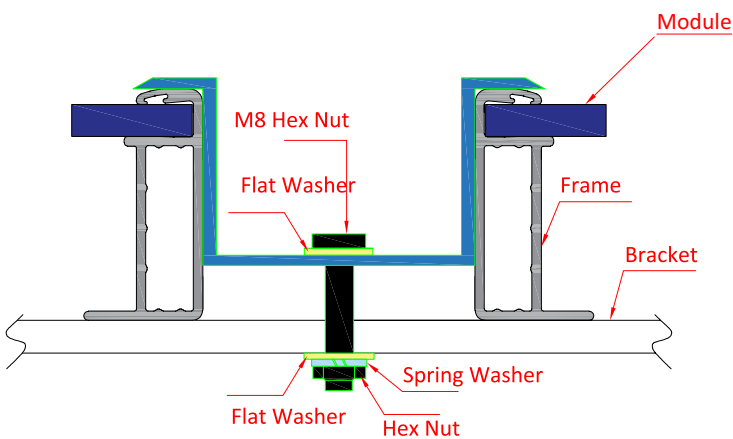

Figure 3 Double-Sided Clamp Installation

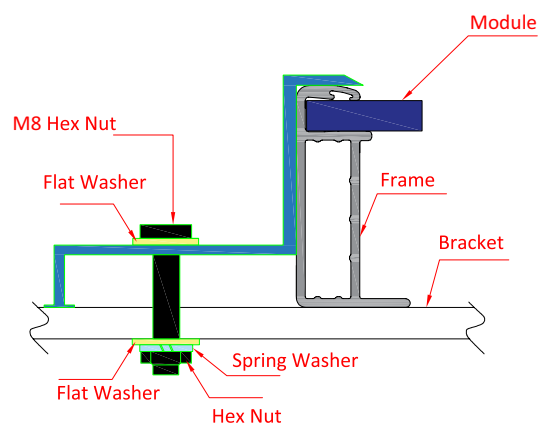

Figure 4 Single-Sided Clamp Installation

To ensure the modules are capable of withstanding a snow load of up to 5400 Pa (550 kg / m²) they must be affixed to the bracket utilizing a minimum of four clamps along the long edge. Verify that at least two purlins are present on the rear side to provide sufficient support for the modules.

The selection and installation of clamps must comply with the specifications outlined in Table 2 failure to adhere to these requirements may result in the module being unable to withstand mechanical loads potentially leading to the risk of breakage.

4.3.2 LONG EDGE INSTALLATION

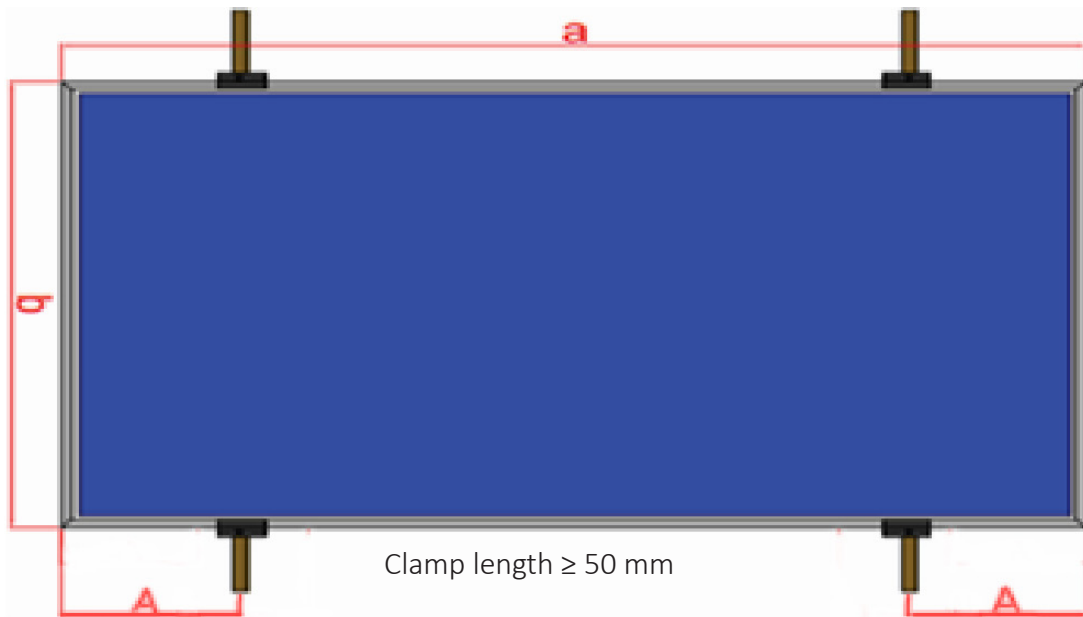

Figure 5

Table 2

Module Type	Module Dimension a*b	Mechanical Strength (Pa)
Bifacial (Glass - Glass) PV Modules	1986*996	A=(300-500)mm Front \leq 5400Pa; Back \leq 2400Pa A=(50-500)mm Front \leq 2400Pa; Back \leq 2400Pa
	2010*1008	
	1664*998	
	1690*1008	
	2045*1008	A=(380-580)mm Front \leq 5400Pa; Back \leq 2400Pa A=(50-580)mm Front \leq 2400Pa; Back \leq 2400Pa
	2094*1038	
	1720*1008	A=(300-500)mm Front \leq 5400Pa; Back \leq 2400Pa A=(50-500)mm Front \leq 2400Pa; Back \leq 2400Pa
	1755*1038	
	1852*1002	A=(300-500)mm Front \leq 5400Pa; Back \leq 2400Pa A=(50-500)mm Front \leq 2400Pa; Back \leq 2400Pa

Module Type	Module Dimension a*b	Mechanical Strength (Pa)
Bifacial (Glass - Glass) PV Modules	2198*1008	A=(380-580)mm Front≤5400Pa; Back≤2400Pa A=(50-580)mm Front≤2400Pa; Back≤2400Pa
	2278*1134	A=(380-580)mm Front≤5400Pa; Back≤2400Pa A=(50-580)mm Front≤2400Pa; Back≤2400Pa
	1909*1134	A=(300-500)mm Front≤5400Pa; Back≤2400Pa A=(50-500)mm Front≤2400Pa; Back≤2400Pa
	2093*1134	A=(300-500)mm Front≤5400Pa; Back≤2400Pa
	1722*1134	A=(300-500)mm Front≤5400Pa; Back≤2400Pa
	2465*1134	A=(450-650)mm Front≤5400Pa; Back≤2400Pa A=(100-650)mm Front≤2400Pa; Back≤2400Pa
	2172*1134	A=(300-550)mm Front≤5400Pa; Back≤2400Pa
	2382*1134	A=(420-520)mm Front≤5400Pa; Back≤2400Pa
	1962*1134	A=(300-550)mm Front≤5400Pa; Back≤2400Pa
	1762*1134	A=(220-450)mm Front≤5400Pa; Back≤2400Pa
	1540*1134	A=(200-400)mm Front≤5400Pa; Back≤2400Pa
	2172*1303	A=(250-440)mm Front≤2400Pa; Back≤1800Pa
	2384*1303	A=(280-480)mm Front≤2400Pa; Back800Pa

Module Type	Module Dimension a*b	Mechanical Strength (Pa)
Monofacial - Bifacial (Backsheet) PV Modules	1956*992 1970*992 1985*1002	A=(380-580)mm Front≤5400Pa; Back≤2400Pa A=(50-580)mm Front≤2400Pa; Back≤2400Pa
	1640*992 1660*992 1665*1002	A=(300-500)mm Front≤5400Pa; Back≤2400Pa A=(50-500)mm Front≤2400Pa; Back≤2400Pa
	1996*992 2015*1002	A=(380-580)mm Front≤5400Pa; Back≤2400Pa A=(50-580)mm Front≤2400Pa; Back≤2400Pa
	2094*1038	A=(380-580)mm Front≤5400Pa; Back≤2400Pa
	1674*992 1690*1002	A=(300-500)mm Front≤5400Pa; Back≤2400Pa A=(50-500)mm Front≤2400Pa; Back≤2400Pa
	1755*1038	A=(300-500)mm Front≤5400Pa; Back≤2400Pa
	1852*1002	A=(300-500)mm Front≤5400Pa; Back≤2400Pa A=(50-500)mm Front≤2400Pa; Back≤2400Pa
	2180*1002	A=(380-580)mm Front≤5400Pa; Back≤2400Pa A=(50-580)mm Front≤2400Pa; Back≤2400Pa
	2279*1134	A=(380-580)mm Front≤5400Pa; Back≤2400Pa
	1909*1134	A=(300-500)mm Front≤5400Pa; Back≤2400Pa A=(50-500)mm Front≤2400Pa; Back≤2400Pa

Module Type	Module Dimension a*b	Mechanical Strength (Pa)
Monofacial - Bifacial (Backsheet) PV Modules	2093*1134	A=(300-500)mm Front≤5400Pa; Back≤2400Pa
	1722*1134	A=(300-500)mm Front≤5400Pa; Back≤2400Pa
	2465*1134	A=(450-650)mm Front≤5400Pa; Back≤2400Pa A=(100-650)mm Front≤2400Pa; Back≤2400Pa
	2172*1134	A=(300-550)mm Front≤5400Pa; Back≤2400Pa
	2382*1134	A=(420-520)mm Front≤5400Pa; Back≤2400Pa
	1962*1134	A=(300-550)mm Front≤5400Pa; Back≤2400Pa
	1762*1134	A=(220-450)mm Front≤5400Pa; Back≤2400Pa
	1540*1134	A=(200-400)mm Front≤5400Pa; Back≤2400Pa
	2172*1303	A=(250-440)mm Front≤2400Pa; Back≤1800Pa
	2384*1303	A=(280-480)mm Front≤2400Pa; Back≤1800Pa

In modules featuring 182 x 210 mm cells, four mounting holes designed in accordance with industry standards have been incorporated into the frames to enhance customer installation efficiency.

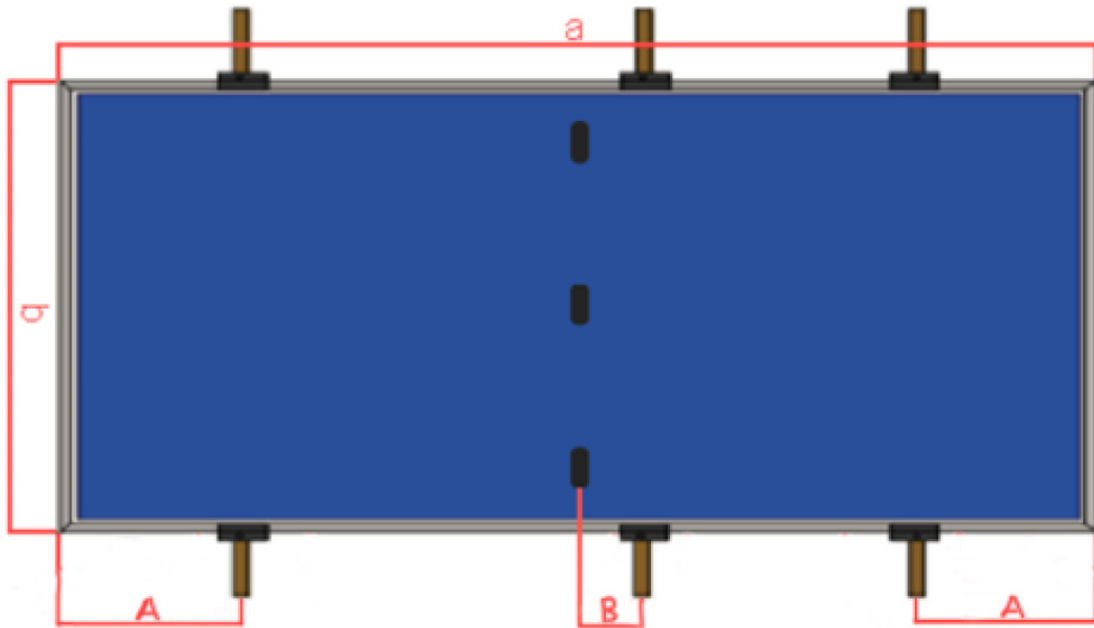

Clamp length ≥ 80 mm

Figure 6

Table 3

Module Type	Module Dimension a*b	Mechanical Strength (Pa)
Bifacial (Glass - Glass) PV Modules	2172*1303	A=(250-440)mm B=(50-100)mm Front \leq 5400Pa; Back \leq 2400Pa
	2384*1303	A=(280-480)mm B=(50-100)mm Front \leq 5400Pa; Back \leq 2400Pa
Monofacial - Bifacial (Backsheet) PV Modules	2172*1303	A=(250-440)mm B=(50-100)mm Front \leq 5400Pa; Back \leq 2400Pa
	2384*1303	A=(280-480)mm B=(50-100)mm Front \leq 5400Pa; Back \leq 2400Pa

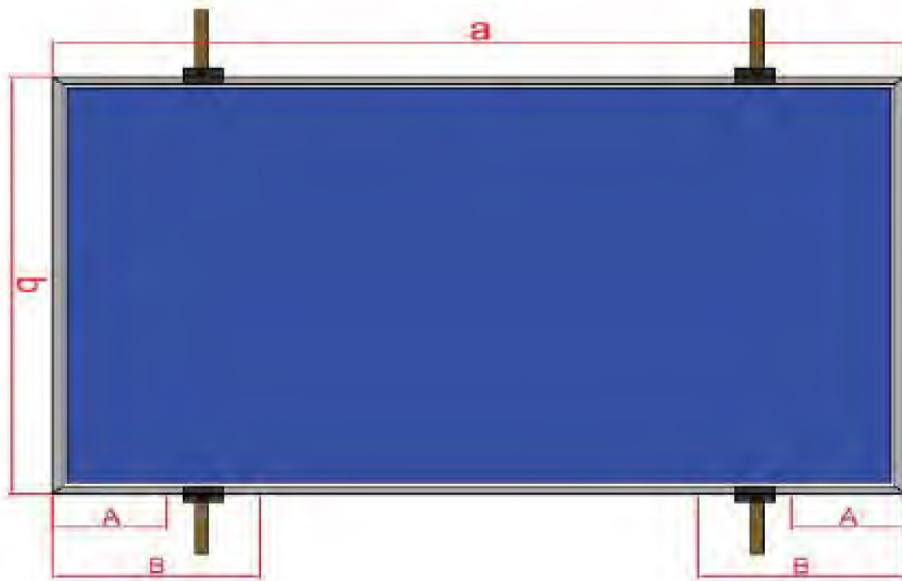

Figure 6.1

Table 3.1 (Applicable to only ELNSM54M-HC and ELNSM54M-HC-N Series assembled in USA)

	a (mm)	b (mm)	Clamp Length	A (mm)	B (mm)	Design Load (Pa)	Test Loads (Pa) 1,5 x Safety
Rear Side	1722	1134	≥50	405	455	3600	5400
Front Side	1722	1134	≥50	405	455	3600	5400

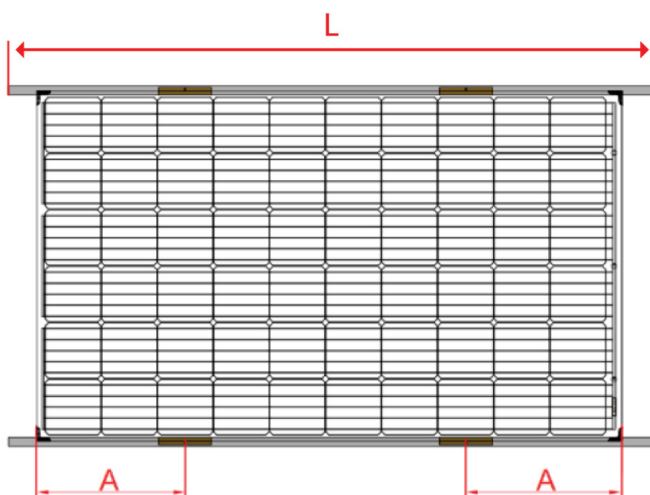

Figure 7

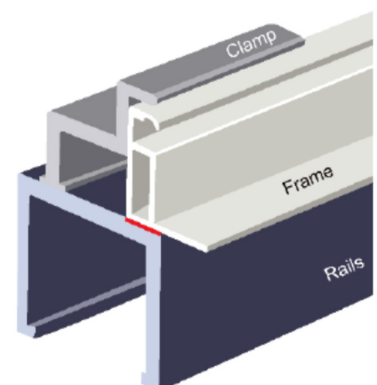

Figure 8

In long-side installation the purlins shall be positioned parallel to the long edge. The PV module frame surface must be oriented in a manner that ensures secure fixation with a clamp at a minimum distance of 15 mm from the mounted structure.

$A=L/4 \pm 50\text{mm}$

4.3.3 SHORT EDGE INSTALLATION



Clamp length \geq 50 mm

Figure 9

Table 4

Module Type	Module Dimension e*d	Mechanical Strength (Pa)
Bifacial (Glass - Glass) PV Modules	2278*1134	A=(100-240)mm Front \leq 1600Pa; Back \leq 1600Pa
	1909*1134	
	2093*1134	
	1722*1134	
	2465*1134	
	2172*1134	
	2382*1134	
	1962*1134	
	1762*1134	
	1540*1134	

Module Type	Module Dimension e*d	Mechanical Strength (Pa)
Monofacial - Bifacial (Backsheet) PV Modules	2279*1134	A=(100-240)mm Front≤1600Pa; Back≤1600Pa
	1909*1134	
	2093*1134	
	1722*1134	
	2465*1134	
	2172*1134	
	2382*1134	
	1962*1134	
	1762*1134	
	1540*1134	

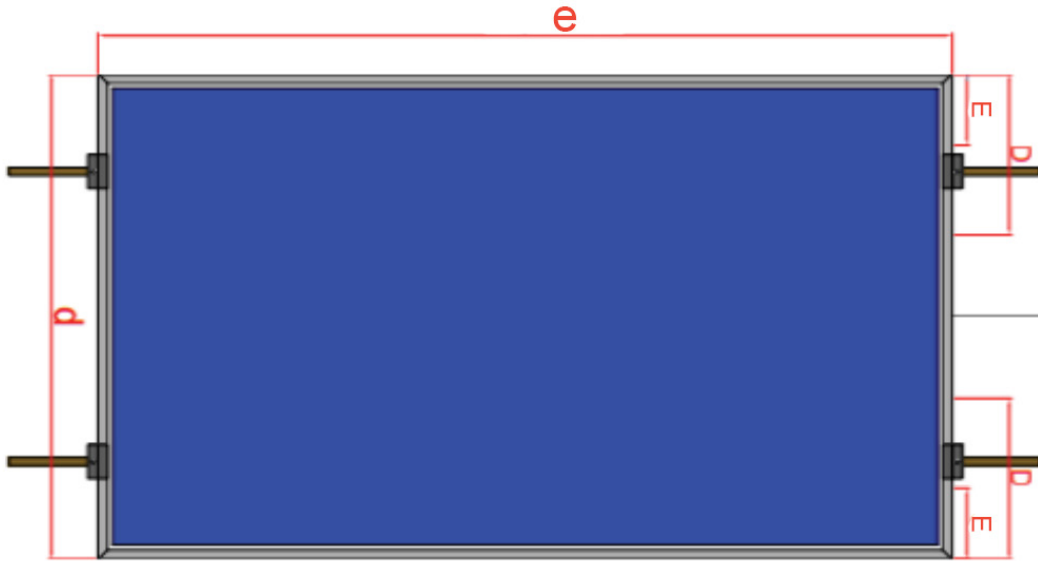

Figure 9.1

Table 4.1 (Applicable to only ELNSM54M-HC and ELNSM54M-HC-N Series assembled in USA)

e (mm)	d (mm)	Clemp Length	E (mm)	D (mm)	Design Load (Pa)	Test Loads (Pa) 1,5 x Safety
1722	1134	≥50mm	100	240	1200	1800

General Requirements for All Mounting Configurations

- The load values listed in the table refer solely to the mechanical durability of the solar modules. Mounting systems and installation components (such as clamps) are not covered by the PV module certification according to IEC 61215/61730 standards. It is the responsibility of the mounting system provider to assess the mechanical performance of the complete mounting solution, including clamps and rails.
- The test load values were established using high-stiffness, reusable test clamps and rails designed to exert the maximum stress on the module during testing. Installers must ensure that the clamps and rails used in the field can securely hold the modules under the specified maximum load conditions.
- Installers are also responsible for assessing and meeting site-specific load requirements, which may vary by location
- Uneven loads, such as snow overhangs or drifts that cause concentrated pressure in certain areas, must be either prevented or removed using appropriate technical measures.

4.4 SCREW INSTALLATION

The framed double-glass module is additionally engineered for mounting with screws. During the installation process screws, bolts, nuts and washers must be utilized to affix the module to the bracket (refer to Figure 12). Adequate torque shall be applied to the bolts to ensure robust reinforcement. The specified torque range for M8 screws is 16-20 N-m. M6 bolts are employed in installations featuring four Nextracker mounting holes. The applied torque must be sufficient to ensure the module is securely fastened.

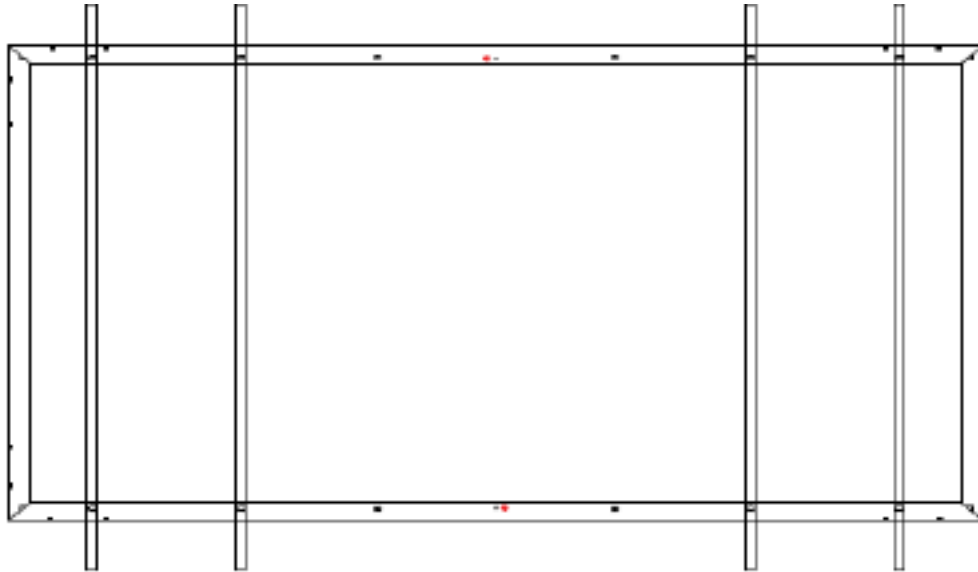

Figure 10 - (8 mounting hole installation is compatible with frames featuring 8 mounting holes.)

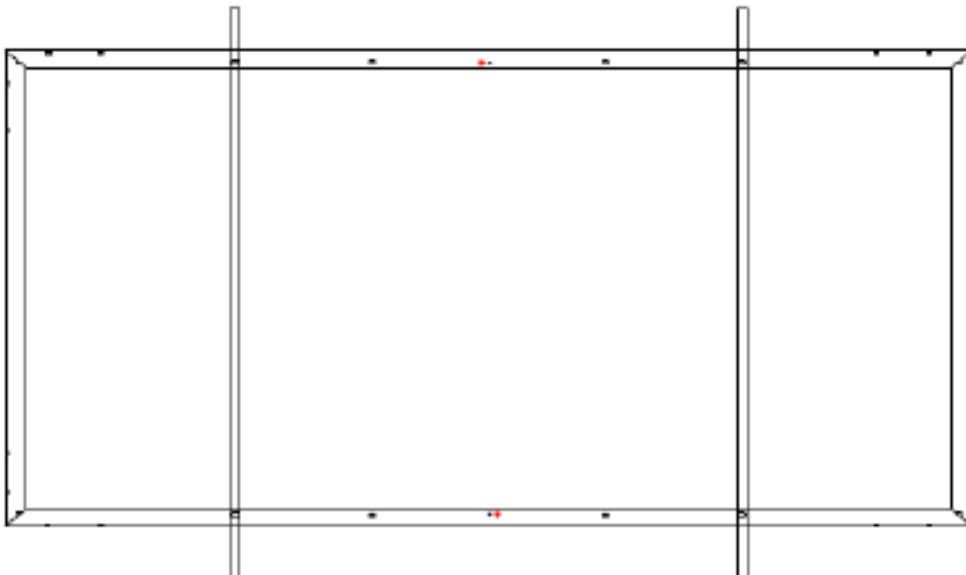

Figure 11 - (4 mounting hole installation is compatible with frames featuring 4 mounting holes.)

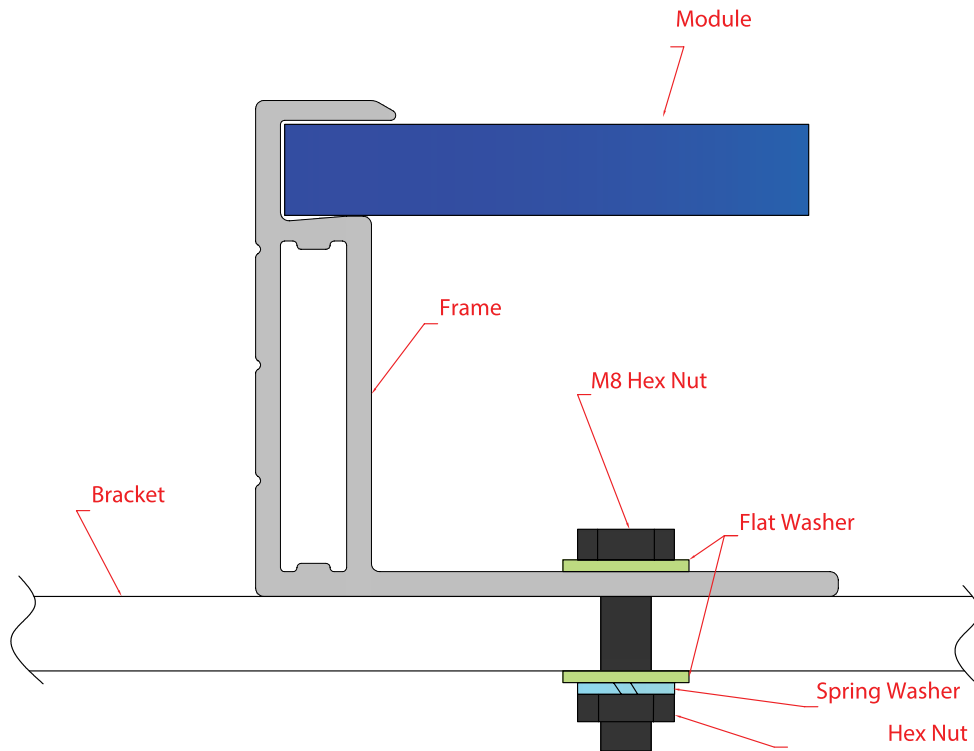

Figure 12 - M8 Screw Installation

To ensure the modules are capable of withstanding a downward force of up to 2400 Pa (244 kg / m²) they must be securely affixed to the bracket utilizing a minimum of four screws along the long edge. Verify that at least two purlins are positioned at the rear to provide adequate support for the modules.

The selection and installation of screws must adhere to the specifications outlined in Table 5 and Table 6. Failure to comply with these requirements may result in the module being unable to withstand mechanical loads thereby posing a risk of breakage.

Table 5



Installation Site	Load (Pa)	Screw Quantity	Installation Drawing
Outer 4 Holes Compatible with frame featuring 8 mounting hole design.	+2400 -2400	4	
Inner 4 Holes Compatible with frame featuring 8 mounting hole design.	+2400 -2400	4	

Table 6

Installation Site	Load (Pa)	Screw Quantity	Installation Drawing
Outer 4 Holes + Outer 4 Holes Compatible with frame featuring 8 mounting hole design.	+5400 -2400	8	
Nextracker Holes	+2400 -2400	4	

For modules incorporating 182 x 210 mm cells four mounting holes designed in accordance with industry standards have been integrated into the frames to enhance customer installation efficiency (as referenced in Table 7).

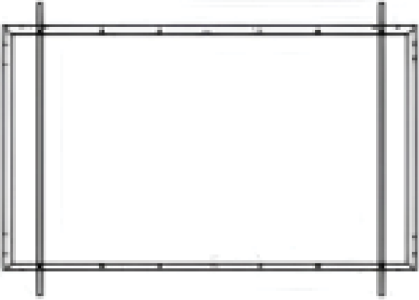
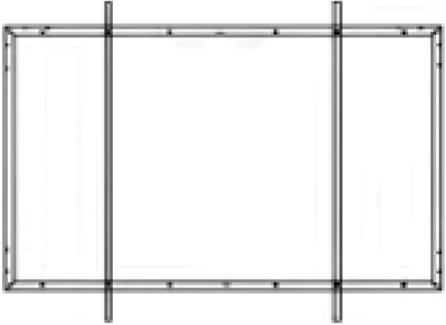
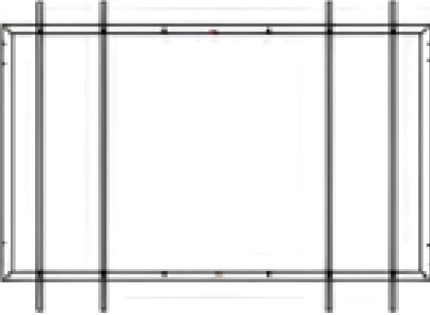
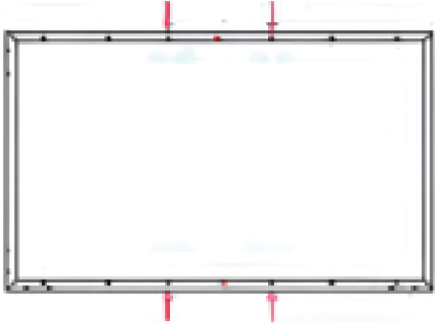
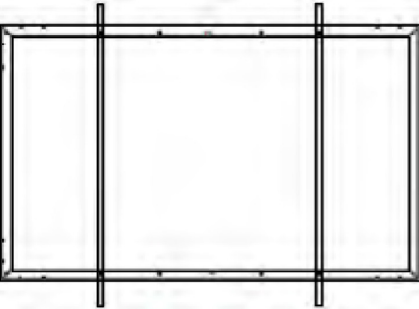
Table 7

Installation Site	Load (Pa)	Screw Quantity	Installation Drawing
<p>Outer 4 Holes Compatible with frame featuring 4 mounting hole design.</p>	<p>+5400 -2400</p>	<p>4</p>	
<p>Nextracker Holes</p>	<p>+2400 -2400</p>	<p>4</p>	

4.5 ELECTRICAL INSTALLATION



WARNING: Electrical Hazard

This module generates electricity when exposed to light. Adhere to all applicable electrical safety protocols.

- Only qualified and competent personnel are authorized to conduct the installation and maintenance of PV modules.
- Exercise caution regarding hazardous high DC voltage during PV module connections.
- Avoid damaging or scratching the rear surface of the PV module.
- Refrain from handling or installing the PV module under wet or damp conditions.
- Ensure that wiring components are fully compatible with the PV modules.
- The current ratings of PV modules connected in series must be closely aligned.
- The open-circuit voltage (Voc) of a PV string must not surpass the maximum system voltage. (refer to the maximum system voltage indicated on the module label)
- When determining the Voc of the PV string account for the module's temperature coefficient for Voc and the extremely low ambient temperature at the installation site.
- PV modules connected in parallel must exhibit comparable voltage levels.
- When determining the short-circuit current (Isc) of the PV string the module's temperature coefficient for Isc and the exceptionally high ambient temperature at the installation site must be duly considered.
- The cross-sectional area, type and temperature rating of system cables must conform to applicable local regulations.
- The cable cross-sectional area and conductor current capacity shall be sufficient to accommodate the PV system's maximum short-circuit current. (for a single component we recommend a minimum cable cross-section of 4 mm² and a connector current rating exceeding 15A. Failure to meet these standards may result in cables and connectors overheating due to excessive current)

Please note:

- The maximum temperature limit for cables is 85 °C and for connectors, it is 105 °C.
- Consultation with a qualified system designer or integrator is mandatory.
- Construction permits, inspections and approvals are generally mandated by local utility authorities.
- Prior to installation verify that the connector is adequately protected and free of foreign matter such as dirt, sand or gravel. Should contamination be present the connector must be cleaned prior to proceeding.
- Damaged or deformed connectors are prohibited from use.
- In the event of connector replacement utilize original spare connectors or contact SIRIUS for assistance.
- When the customer is performing series connections the connector from the same panel should be utilized. Where feasible the existing connector on the module should be removed and substituted with the customer's connector.

Note: Should a conversion cable be required, please consult Attachment-1 for detailed specifications.

4.6 GROUNDING

When installing a listed grounding or bonding device utilizing common grounding hardware (e.g. nuts, bolts, star washers, lock washers, flat washers or similar components) additional procedures must be executed in accordance with the manufacturer’s guidelines for the grounding device. Consult applicable regional and national electrical and safety standards to ensure compliance with grounding and bonding requirements. If grounding is deemed necessary, employ the recommended connector type for the grounding conductor or an equivalent approved component. The grounding conductor shall be securely and accurately affixed to the PV module frame to guarantee dependable electrical continuity (refer to Figure 13 for the designated grounding hole). For systems functioning in environments characterized by high humidity and elevated temperatures, the adoption of a transformer-based inverter with negative grounding capability is highly recommended to mitigate the risk of enhanced power degradation.

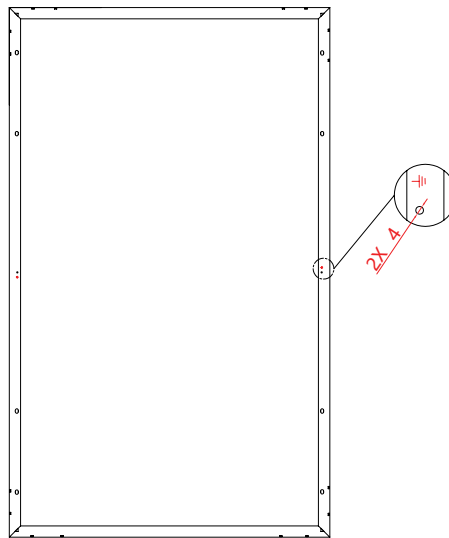

Figure 13

| 5 MAINTENANCE

To ensure optimal performance, regularly clean the module’s glass surface using clean water and a soft, non-abrasive sponge or cloth. For persistent dirt, a gentle, non-abrasive cleaning solution may be applied. Avoid using water with high mineral content as it may leave residues or cause damage to the surface. Cleaning intervals should be determined based on the environmental pollution levels in the installation area. Inspect all electrical, grounding and mechanical connections at least every six months to confirm they are clean, secure, intact and free from corrosion. If any issues are identified seek guidance from a qualified technician.

Caution: Always follow the manufacturer’s maintenance guidelines for all system components including structural supports, charge controllers, inverters, batteries and related equipment.

| 6 PARAMETERS

Please note that technical parameters are subject to periodic updates. For the most current and accurate specifications, refer to our official website: www.siriuspv.com

Note: This Installation Guide remains valid until superseded by a revised version.

Mounting Guidance

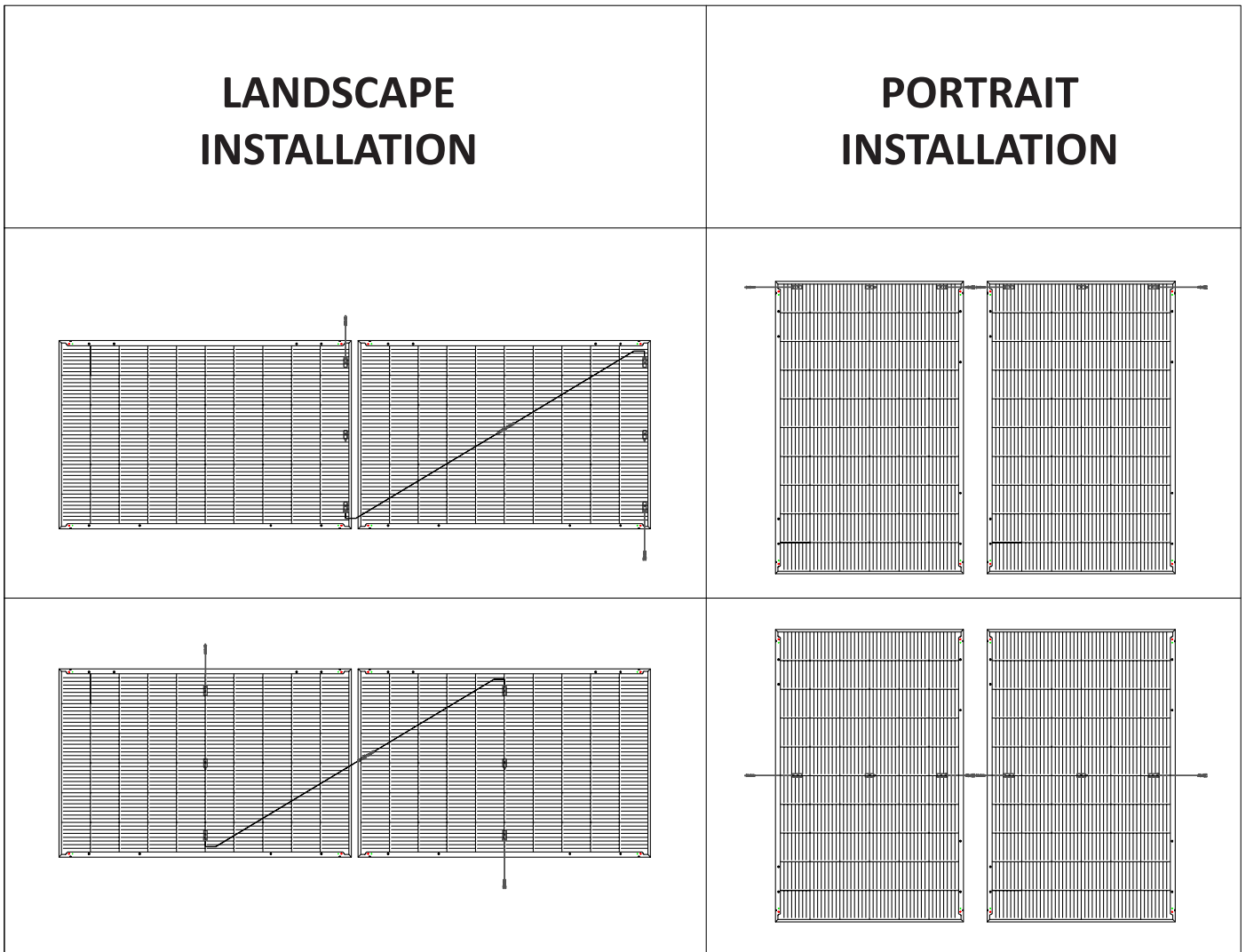

LANDSCAPE INSTALLATION

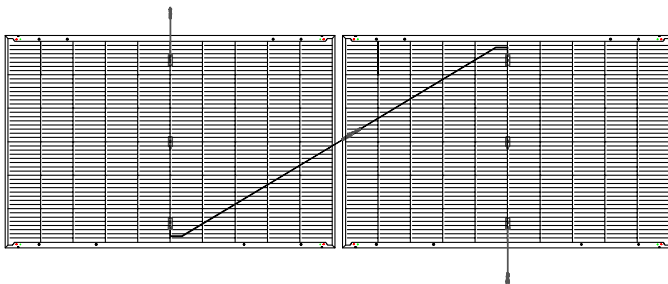
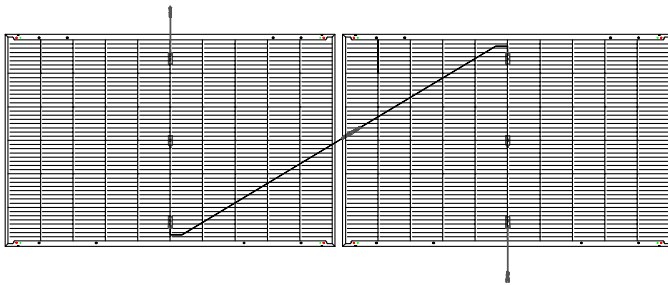
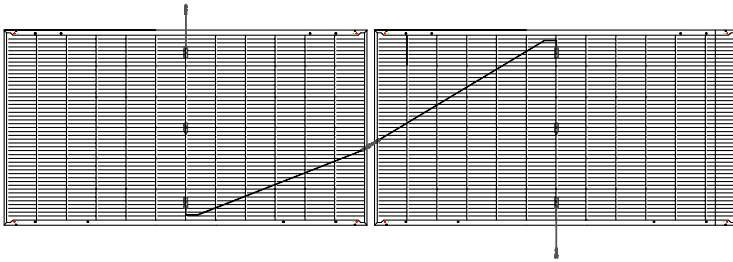

PORTRAIT INSTALLATION

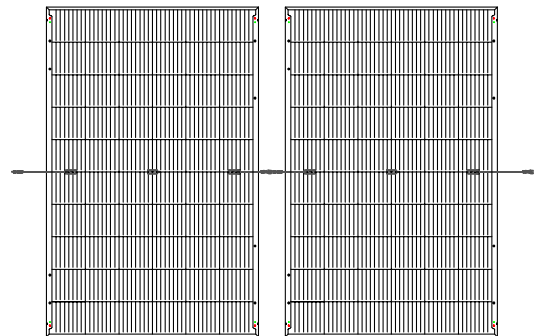
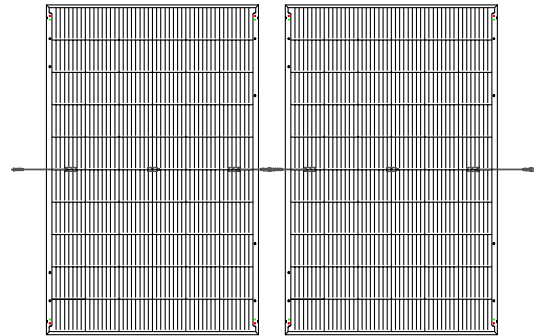
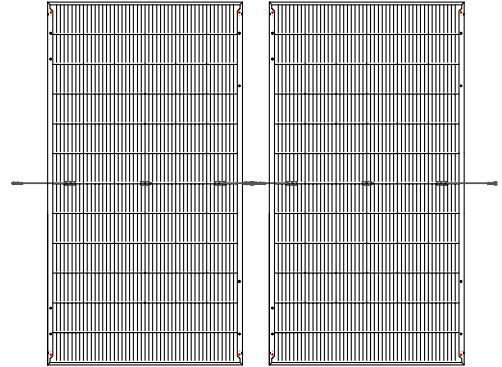

ATTACHMENT 1

INSTRUCTIONS FOR USE OF CONVERSION CABLES

Conversion cables must be used under the following conditions:

1. When the DC-side input terminal of the inverter or combiner box is equipped with an original MC4 connector.
2. When the inverter or combiner box manufacturer requires a series DC input bus terminal that uses an MC4 connector.

Pre-Use Inspection Checklist:

1. Verify that the MC4 connector on the conversion cable is original and compatible with the system's MC4 interface.
2. Ensure that the connector is firmly attached to the cable with no signs of loosening, detachment or water damage. Check that the metal core is not misaligned, stained or otherwise compromised.
3. Inspect the cable insulation for any signs of damage. The cable must not be twisted, bent excessively or otherwise deformed.

Installation of conversion cable:

1. Determine the cable installation points: The positive terminal of the string corresponds to the positive terminal of the first junction box in the string. Similarly the negative terminal of the string corresponds to the negative terminal of the last junction box in the string.
2. Connect the positive terminals: Insert the positive terminal of the string into the negative terminal of the compatible conversion cable. Then connect the other end of the conversion cable (with the original MC4 connector) to the DC positive input terminal of the inverter or combiner box.
3. Connect the negative terminals: Insert the negative terminal of the string into the positive terminal of the compatible conversion cable. Then connect the other end of the conversion cable (with the original MC4 connector) to the DC negative input terminal of the inverter or combiner box.

1. Refer to the schematic diagram below for visual installation guidance.

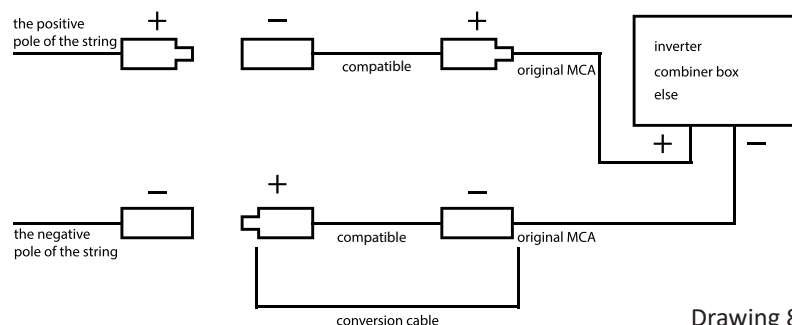

Precautions:

1. Ensure that the string polarity after connection matches the polarity requirements of the inverter or combiner box.
2. During installation and operation, strictly follow the provided schematic diagram. Do not reverse polarity or alter the intended connection sequence.
3. Each DC string must be connected to only one pair of conversion cable wires. Improper use such as repeatedly connecting multiple extension wires is strictly prohibited and may result in system failure.